

STATIC OVEN / 1 DOOR

# ROMA

EASY RIF. COD. E



**M.A.M. s.r.l.**  
Via C. Angiolieri, 28-34  
41123 Modena (Italy)  
Tel. +39 059 330219  
mam@mamforni.it  
P. IVA 02170610360



[www.mamforni.it](http://www.mamforni.it)

## TECHNICAL CHARACTERISTICS

MODEL	UM	Ø 80
Height of the cooktop	cm	120
Door width	cm	46
Total weight (standard finish)	Kg	600
Pizza capacity	n.	3 - 4

Minimum flue dimensions: Ø 20 cm

DIMENSIONS	UM	75 x 80
A - DEPTH	cm	117
B - WIDTH	cm	104
C - HEIGHT	cm	190
D	cm	120
E	cm	92
F	cm	70
G	cm	88
Headband foot overhang	cm	12

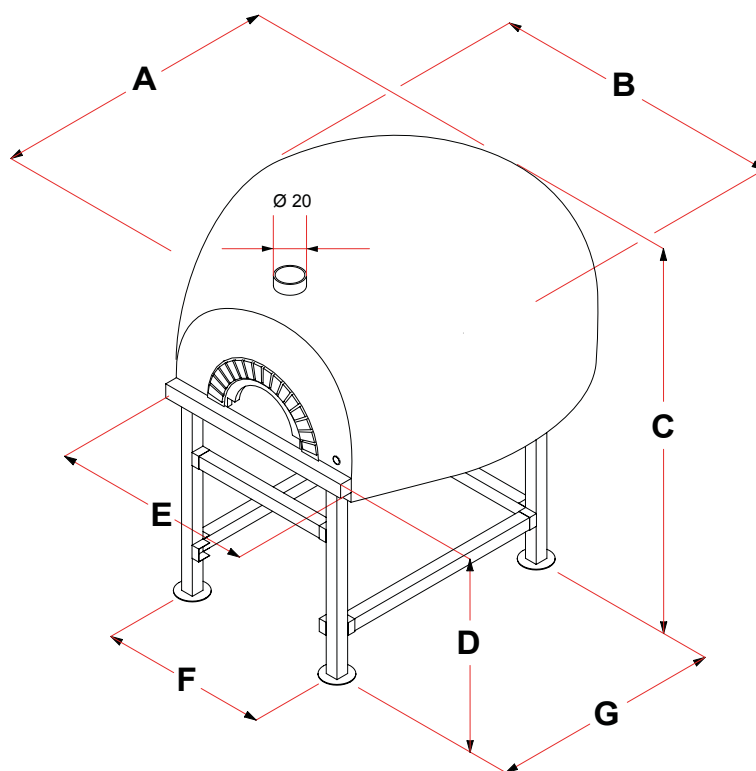
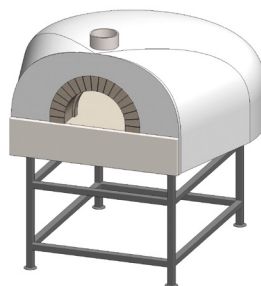

## WOOD DATA

Minimum distance from the combustible material	Contact
CO emission produced during combustion	0,48 %
Combustion fume temperature	305° C
Thermic outlet used (heating)	11,5 Kw
Energy efficiency	66,7 %
Fuel typer	Wood logs
CO** (mg/Nm <sup>3</sup> )	5848
Powders** (mg/Nm <sup>3</sup> )	248

MADE IN ITALY **CE** 05

Prefabricated wood-fired oven  
1935/2004 -2001/95/CE

\*\* values corrected to 10% of O<sub>2</sub>

