

# FORNO STATICO / 1 BOCCA

# MILANO

## TRADIZIONALE RIF. COD. T



**M.A.M. s.r.l.**  
Via C. Angiolieri, 28-34  
41123 Modena (Italy)  
Tel. +39 059 330219  
mam@mamforni.it  
P. IVA 02170610360



[www.mamforni.it](http://www.mamforni.it)

### CARATTERISTICHE TECNICHE

MODELLO	UM	Ø 140
Altezza piano di cottura	cm	120
Larghezza bocca	cm	54/68/82
Peso totale (finitura standard)	Kg	1800
Capienza pizze	n.	10 - 12

Dimensioni minime canna fumaria: Ø 20 cm.

DIMENSIONI	UM	Ø 140
A - PROFONDITÀ	cm	185
B - LARGHEZZA	cm	180
C - ALTEZZA	cm	200
D	cm	120
E	cm	116
F	cm	109
G	cm	129
Sporgenza piedi frontale	cm	18

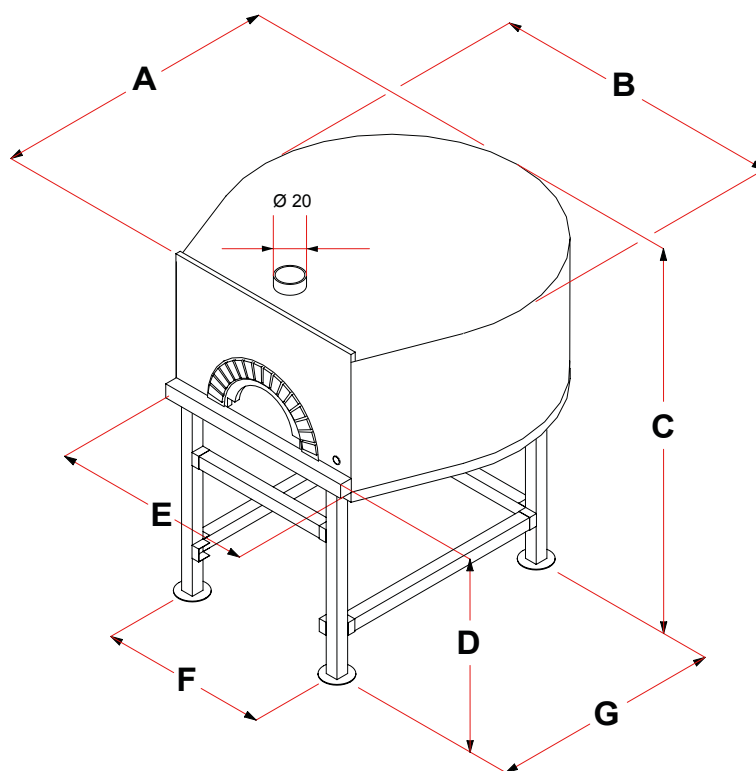
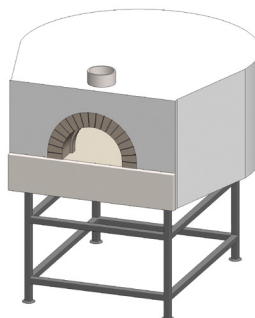

### DATI LEGNA

Distanza Minima del materiale combustibile	Contatto
Emissione di CO prodotta in combustione	0,48 %
Temperatura del fumo di combustione	305° C
Uscita termica utile (riscaldamento)	11,5 Kw
Efficienza dell'energia	66,7 %
Tipo di combustibile	Legno in pezzi
CO (mg/Nm³)	5848
Polveri (mg/Nm³)	248

MADE IN ITALY **CE** 05

Forno a legna prefabbricato  
1935/2004 - 2001/95/CE

